



cANTIdAd  
dE PuErTAS



SISTEMA  
dENTro dE VANo



cAPAcIdAd dE  
cArGA Por HoJA



ESPESor  
dE PuErTA

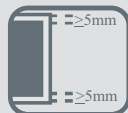

luz  
rIEl / PuErTA

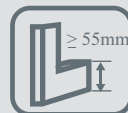

AITurA MARco  
dE PuErTA



MoNTAJE  
FroNTAl



rodAMIEnto



Riel superior D-52 aluminio



Riel inferior D-52 aluminio



D-52



Se trata de un Sistema Corredizo de deslizamiento recto del tipo de apoyar, para puertas de closet tanto en madera como así también con marco de aluminio.

La guía continua superior es de aluminio al igual que el riel.

El elemento que vincula la puerta con la guía continua es una guía de roce plana.

#### uSoS

- | Puertas de madera y metal
- | Puertas espejadas de placard

#### CUALIDADES

- | Los carros pueden colocarse embutidos o sobrepuestos de acuerdo a la luz que se desee obtener entre puertas.
- | Tope de goma que evita el traslape de las hojas.
- | Puede instalarse tanto en puertas de madera como con marco de aluminio.
- | Al tener un sistema de guías y rieles independientes, permite trabajar con puertas de distintos espesores.

SISTEMAS corrEdIzoS PARa  
PuErTAS dE PlAcArD

D-52

LINEA  
Mobile<sup>®</sup>



RESISTENCIA CÁMARAS ANSI - bHMA  
NIEBLA SALINA



d-52  
| para 2 Hojas |

código 01-002

**A** 4 Carros D-52



**B** 4 Clip



**C** 1 Tope de goma



**D** Tornillos

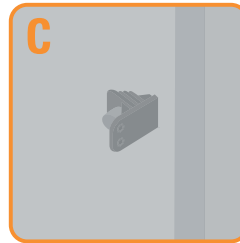
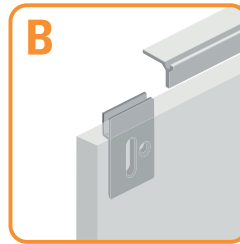
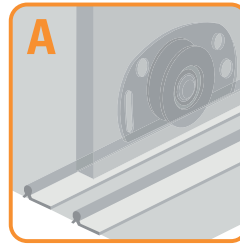
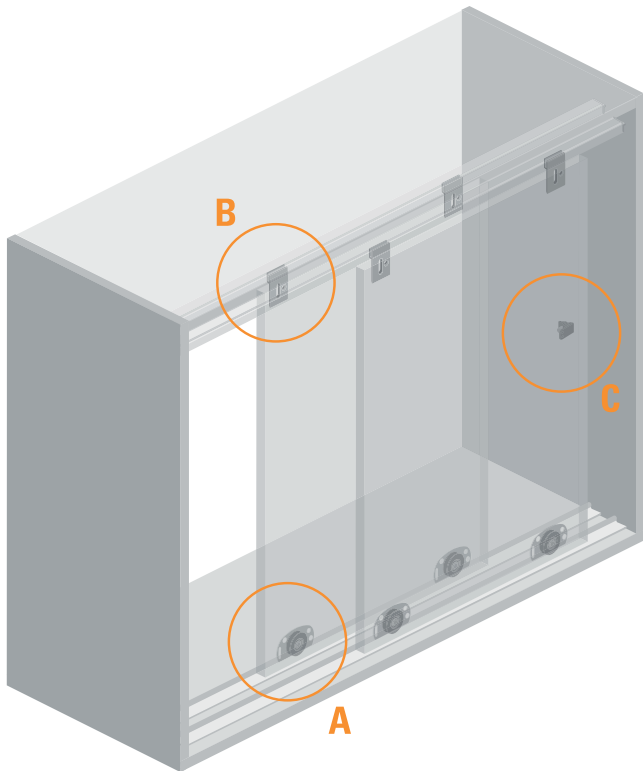

Vereda

Vereda

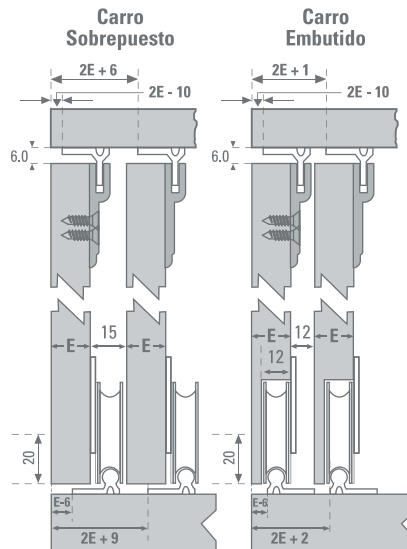
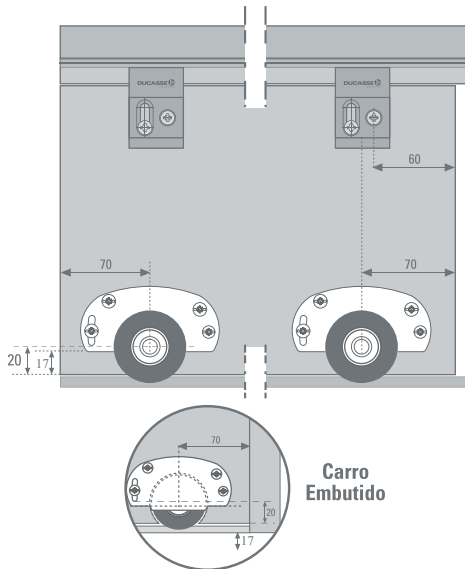

Riel superior D-52 aluminio  
2 m. cód. 07-009  
3 m. cód. 07-011



Riel inferior D-52 aluminio  
2 m. cód. 07-008  
3 m. cód. 07-010

(\*)Todas las medidas están expresadas en milímetros. (\*\*) Estas medidas son sólo referencia, para instalación consulte instructivo de montaje.



Nº OF DOORS  
x KIT



INLAY  
DOOR SYSTEM



BYPASS  
DOOR SYSTEM



MAX DOOR  
WEIGHT



DOOR  
THICKNESS

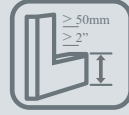

MIN DOOR  
FRAME HEIGHT



DOOR  
MATERIAL



GAP DOOR-GUIDE  
GAP DOOR-TRACK



Carrier Track CXE



Carrier AL 1535 Wood



Carrier Track CXE



**DESCRIPTION**

- Floor sliding system for wood bypass doors up to 15 kg (33 lbs).

**APPLICATIONS**

- Ideal for furniture applications.
- System travels inlay the opening

**FEATURES**

- Clip on upper guide allows for easy mount and dismount of your door.
- Stoppers with retention device installed inside the track will retain the door in position.
- One box with all you need to install 2 doors, order the track, and you are ready to go.
- Aluminum anodized track flush mounted for a concealed clean look.
- Same track top and bottom for easier installation.
- Premium Ball bearing quality rollers for a silent and smooth glide.
- Carrier perforations are in system 32, for mechanical installations.



SALINITY TEST



ANSI-BHMA \*



SYSTEM 32



ROLLER

CARRIER TRACK



FLUSH MOUNT TRACK CXE



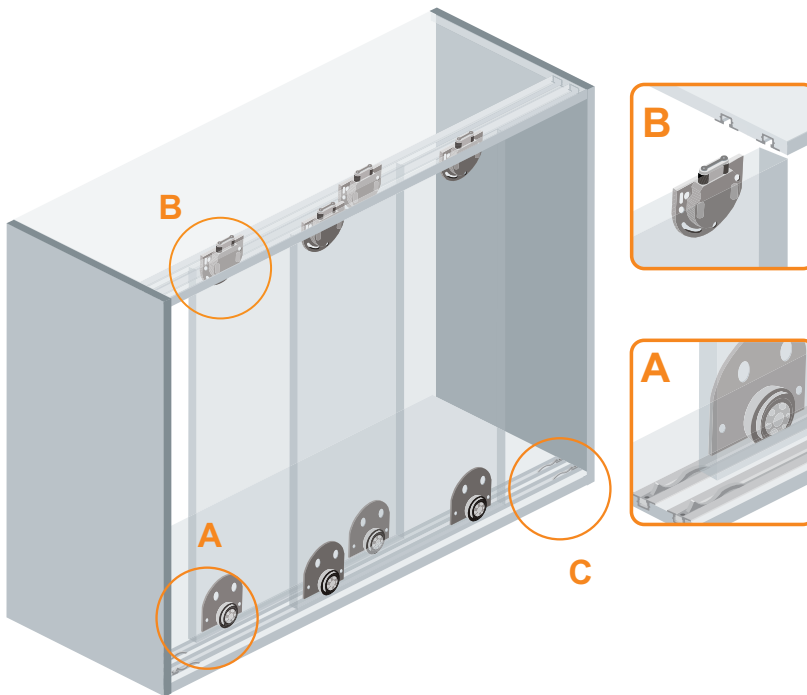

PART NUMBER	DESCRIPTION
• 021CXE1	Track CXE AL 2m (6.5 ft)
• 021CXE2	Track CXE AL 3m (9.85 ft)

MASTER PACK: 10 units

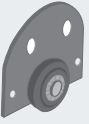

AL 1535 for Wood doors,  
carrier set for 2 doors

PART NUMBER: 012103

- A** 4 Carriers AL1535 
- B** 4 Top guides with clip device 
- C** 4 Stoppers AL 1535 
- D** Screws 

MASTER PACK: 10 sets

MASTER PACK SIZE: 8"25/32 x 7"13/32 x 7"11/64

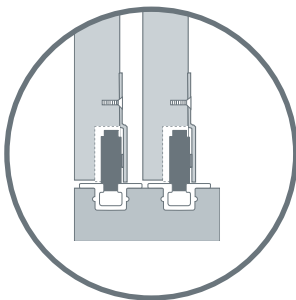

CARRIER INSTALLATION

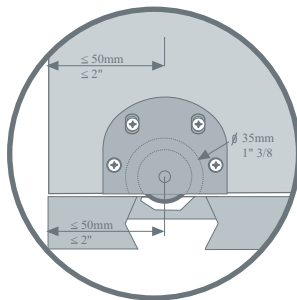

GUIDE INSTALLATION

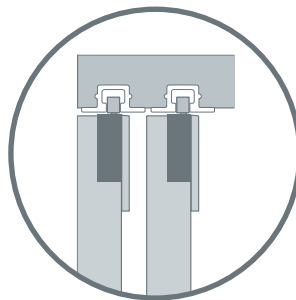

ALL DIMENSIONS ARE IN MM., CM., KG. USA DIMENSIONS ARE APPROXIMATE

(\*) Product tested using ANSI-BHMA protocol. For more information see the glossary of terms



CANTIDAD  
DE PUERTAS



SISTEMA  
DENTRO DE VANO



SISTEMA  
FUERA DE VANO  
CON CONECTOR MURO



CAPACIDAD DE  
CARGA POR HOJA

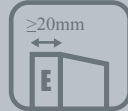

ESPESOR  
DE PUERTA

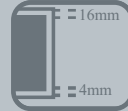

LUZ  
RIEL / PUERTA



RODAMIENTO



MATERIAL  
PUERTA



DN80 CF



Riel U21 RT | Riel U21 CA

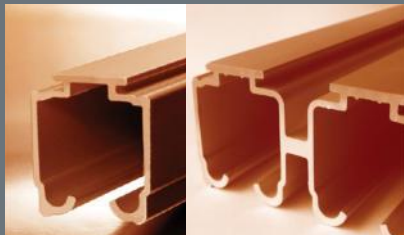

Riel U21 AL | Riel U21 doble



Sistema para puertas  
ocultas, con freno y riel de aluminio.

### CUALIDADES

- | Freno incorporado evita el rebote de las puertas.
- | Su placa de montaje permite la inserción del perno de manera frontal, facilitando su instalación.
- | La placa de montaje se puede soldar o apernar.
- | Riel de aluminio entrega una estética y funcionamiento mejorado.
- | Las cenefas corta y larga permiten una excelente terminación.
- | Conector lateral al muro, permite la instalación del riel al muro.

### USOS

- | Puertas de closet
- | Puertas escondidas
- | Accesos de salas de reuniones y oficinas



LÍNEA  
CONVENCIONAL

DN80 CF



ANSI - BHMA  
UNE - EN



RESISTENCIA CÁMARA  
NIEBLA SALINA

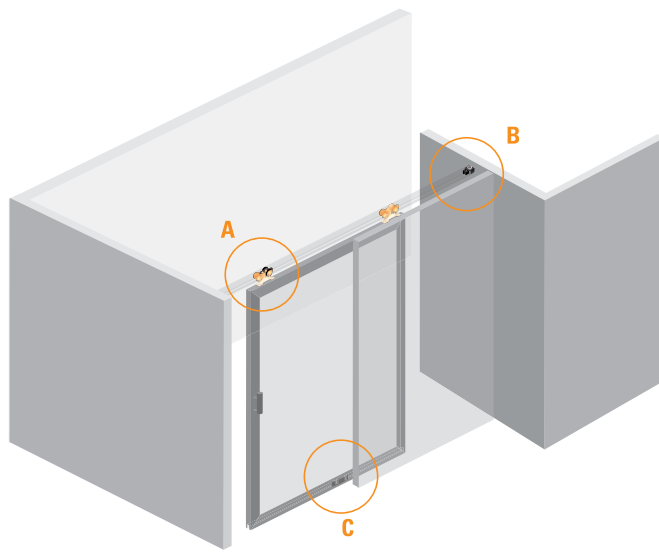

Vista Frontal

Vista Lateral

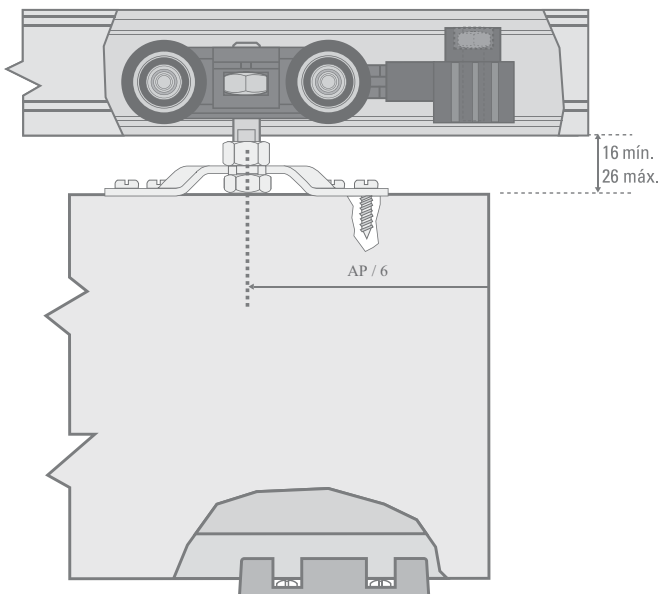

AP = Ancho de Puerta

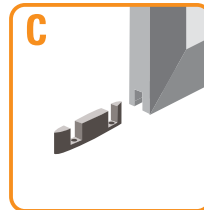
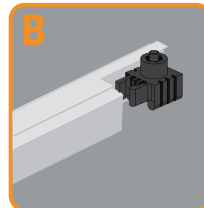
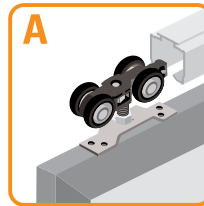

LÍNEA  
SEGMENTA

DN80 CF  
| para 1 Hoja |

10100217471

Mínimo de despacho: 10 unidades

**A** 2 Carros DN80



**B** 2 Frenos



**C** 1 Guía GP-12



**D** 2 Placas de montaje



**E** Tornillos

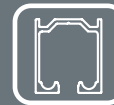

RIEL U21 RT  
2.0 m. 10100626082  
3.0 m. 10100626083  
6.0 m. 10100626086

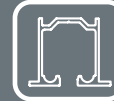

RIEL U21 CA  
2.0 m. 10100626092  
3.0 m. 10100626093  
6.0 m. 10100626096



RIEL U21 AL  
2.0 m. 10100626020  
3.0 m. 10100626030  
6.0 m. 10100626060



RIEL U21 DOBLE  
2.0 m. 10100603020  
3.0 m. 10100603030  
6.0 m. 10100603060

ACCESORIOS



**Conector muro**  
ref. 10100626100



**Conector muro ancho**  
ref. 10100626105



**Cenefa U21 66x8**  
2.0 m. 10100627022  
3.0 m. 10100627032  
6.0 m. 10100627062



**Tapa U21 cenefa 66x8**  
ref. 10100910018



**Guía GPR 8.5**  
ref. 10100900519

# Ducloset DoBle

SISTEMAS corrEdIzoS PARa  
PuErTAS dE PlAcArD



cANTIdAd  
dE PuErTAS



SISTEMA  
dENTro dE VANo



cAPAcIdAd dE  
cArGA Por HoJA

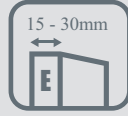

ESPESor  
dE PuErTA

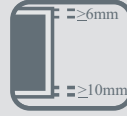

luz  
rIEl / PuErTA



MATErIAl  
PuErTA



MATErIAl  
PuErTA



MoNTAJE  
INclINAdo



Riel U-20 acero zinc



Ducloset doble



Se trata de un Sistema Corredizo de deslizamiento recto, para puertas de placard tanto en madera como así también con marco de aluminio.

Las hojas cuelgan de un riel de acero cincado a través del sistema de carros y en la base, son guiados por un sistema de guía puntual que permite mantener alineado el panel durante su recorrido.

uSoS

| Puertas de placard

## CUALIDADES

- | Se vinculan entre sí a través de un sistema de carros planos y acodados, que de acuerdo al espesor de placa variaran su posición (interior-exterior).
- | Es de muy fácil y rápida instalación y no requiere mecanizados en las puertas.
- | La forma del riel y el alineamiento de la guía al piso entregan mayor seguridad de sujeción.
- | Se puede utilizar tanto en puertas de madera como en marcos de aluminio, ambos de entre 15 y 30 mm. de espesor.
- | Posee un tope de goma que evita el traslape de las puertas.

SISTEMAS corrEdIzoS PARa  
PuErTAS dE PlAcArD

Ducloset  
DoBle

LINEA  
**Mobile<sup>1</sup>**



PERforAcIoNES



rodAMIENTo



rESISTENcIA cÁMArAANSI - bHMA  
NIEblA SAInA



G° 1

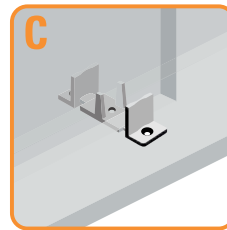
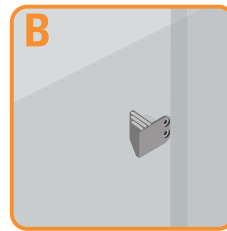
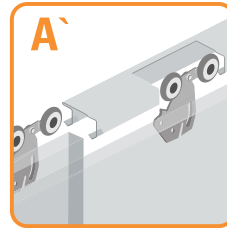
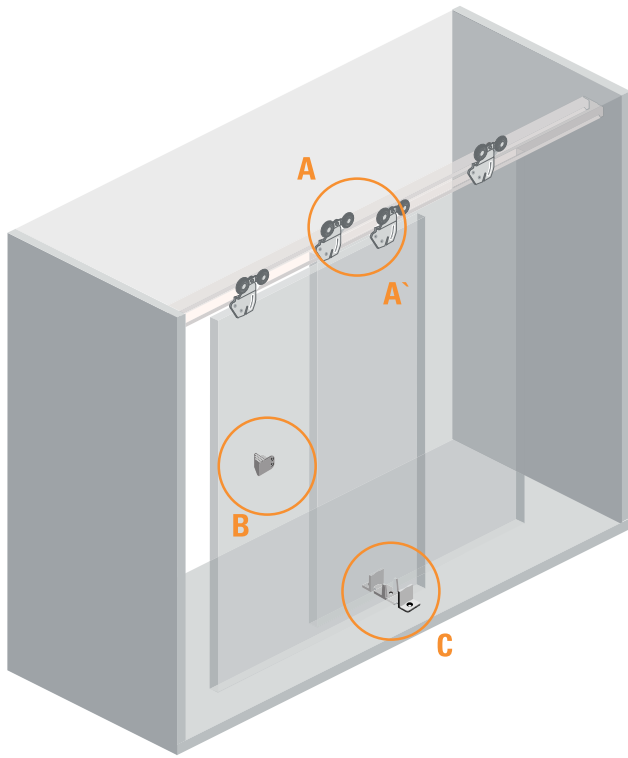

ducloset simple  
| para 2 Hojas |

código 02-001

- A** 2 Carros planos simples  
2 Carros acodados simples



- B** 1 Tope de goma



- C** 1 Guía al piso



- D** Tornillos

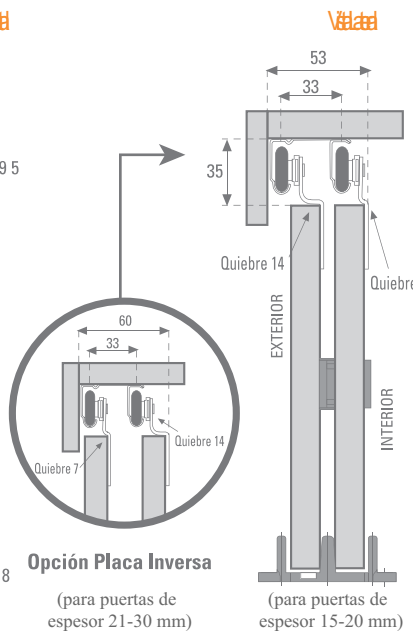
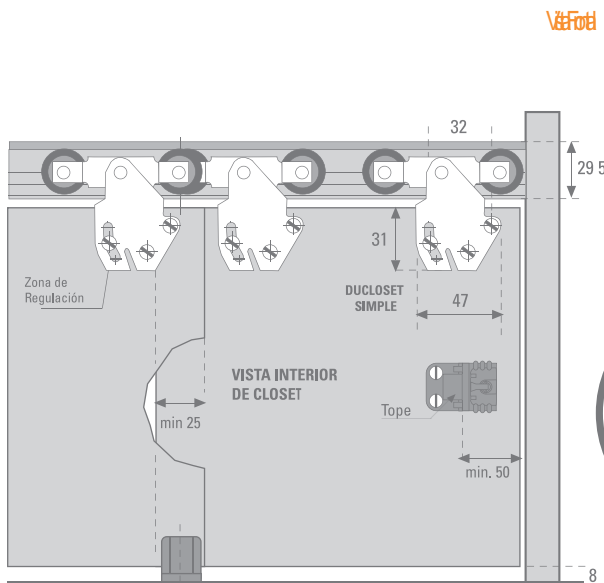

Riel u-20 aceRo zinc 2 mts  
2 m. cód. 06-001  
3 m. cód. 06-002

(\*)Todas las medidas están expresadas en milímetros. (\*\*) Estas medidas son sólo referencia, para instalación consulte instructivo de montaje.